

### Overview

#### HPE Smart Array P824i-p MR Gen10 Controller

The HPE Smart Array P824i-p MR Gen10 Controller, a 12 Gb/s SAS RAID controller with 24 SAS lanes, provides enterprise-class storage scalability to meet your growing capacity needs. It delivers data protection with advanced RAID levels and includes 4 GB Flash-Backed Write Cache (FBWC). It also offers enterprise-level performance and scalability for up to 24 internally attached SAS and SATA drives without the need for the SAS Expander Card providing point to point connectivity to SSDs for lower latency.



#### Models

HPE Smart Array P824i-p MR Gen10 (24 Internal Lanes/4GB Cache/CacheCade) 12G SAS PCIe Controller (Recommended)	870658-B21
--	------------

**Kit Contents:** P824i-p controller

#### Required Battery Option Sold Separately

HPE 96W Smart Storage Battery (up to 20 Devices) with 145mm Cable Kit (Recommended)	P01366-B21
---	------------

HPE 96W Smart Storage Battery (up to 20 Devices) with 260mm Cable Kit (Recommended)	P01367-B21
---	------------

**NOTE:** The Smart Storage Battery supports multiple devices. See server QuickSpecs for compatibility.

#### Required Cable Option Sold Separately

HPE DL38X/560/580/ML350 Gen10 P824i-p Cable Kit (Recommended)	P00614-B21
---	------------

**NOTE:** Supported on HPE ProLiant DL380, DL385, DL560, DL580, and ML350 Gen10 servers.

HPE DL360 Gen10 P824i-p Cable Kit (Extended)	867992-B21
--	------------

**NOTE:** Supported on HPE ProLiant DL360 Gen10 server.

## Standard Features

### Key Features

- Storage interface (SAS/SATA)
  - 24 SAS lanes across 6 x4 internal Mini-SAS HD ports
  - 12Gb/s SAS, 6Gb/s SATA technology
  - Mix-and-match SAS and SATA drives to the same controller
- 4 GB Flash-Backed Write Cache (FBWC)
- PCI Express 3.0 x8 link
- RAID 0, 1, 5, 6, 10, 50, 60
- Mixed Mode (RAID logic drives and HBA physical drives simultaneously)
- UEFI System Utilities (storage configuration)
- Up to 240 physical drives
- Up to 64 logical drives
- HPE Smart Array MR CacheCade (SSD caching)
- HPE SSD Fast Path (SSD acceleration)
- Online firmware updates
- Online capacity expansion
- Automatic drive rebuilds
- Adjustable task rates
- Consistency checks
- Fast initialization
- Patrol read
- Global spare and dedicated spare support

**NOTE:** HPE Smart Array P824i-p MR Gen10 Controller does not support all the same tools or features as the HPE Smart Array SR Gen10 Controllers such as HPE SSA and HPE Smart Array SR Secure Encryption.

<b>Ports</b>	<ul style="list-style-type: none"> <li>• Internal: 24 SAS/SATA lanes across 6 x4 Mini-SAS HD ports</li> </ul>
<b>Form Factor</b>	<ul style="list-style-type: none"> <li>• PCIe Plug-in Controller (occupies a PCIe Expansion Slot)</li> </ul>
<b>Performance</b>	<ul style="list-style-type: none"> <li>• 12Gb/s SAS (1200 MB/s theoretical bandwidth per SAS lane)</li> <li>• 6Gb/s SATA (600 MB/s theoretical bandwidth per SAS lane)</li> <li>• PCI Express 3.0 x8 link width</li> <li>• 4 GB 72-bit wide DDR3-1600 Flash-Backed Write Cache provides up to 12.8 GB/s maximum cache bandwidth</li> </ul>

### Warranty

The warranty for this device is 3 years parts only.

#### Warranty Upgrade Options

- Response - Upgrade on-site response from next business day to same day 4 hours
- Coverage - Extend hours of coverage from 9 hours x 5 days to 24 hours x 7 days
- Duration - Select duration of coverage for a period of 1, 3, or 5 years
- Warranty upgrade options can come in the form of Care Packs, which are sold at the HPE System level to which this product attaches

### Additional Info

For more detailed information on the various features please see the [HPE Smart Array P824i-p MR Gen10 User Guide](#). For a more detailed breakout of the available Gen10 Smart Array controllers visit the [HPE Smart Array Gen10 Controllers Data Sheet](#).

## Compatibility

**Server Support**

- HPE ProLiant DL360 Gen10
- HPE ProLiant DL380 Gen10
- HPE ProLiant DL385 Gen10
- HPE ProLiant DL560 Gen10
- HPE ProLiant DL580 Gen10
- HPE ProLiant ML350 Gen10

**Operating Systems**

- Microsoft Windows Server
- Microsoft Windows Hyper-V Server
- Red Hat Enterprise Linux (RHEL)
- SUSE Linux Enterprise Server (SLES)
- VMware ESXi

**NOTE:** For more information on HPE's server operating systems and virtualization software, please visit: <http://www.hpe.com/info/ossupport>

**Storage Management Software Suite**

- HPE MR Storage Administrator
- HPE StorCLI
- UEFI System Utilities (storage configuration)

**NOTE:** For additional information see the HPE MR Storage Administrator User Guide at: <http://www.hpe.com/info/P824i-pdocs>

**Naming Framework** The Gen10 controller naming framework has been updated to simplify identification as depicted below.

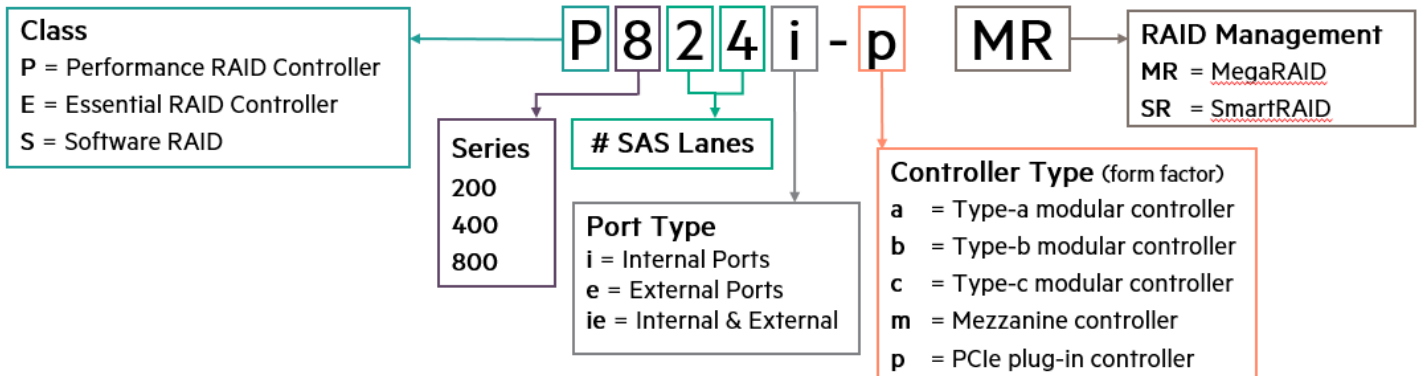

---

## Service and Support

### HPE Support Services

#### Protect your business beyond warranty with HPE Support Services

HPE Pointnext provides a comprehensive portfolio including Advisory and Transformational, Professional, and Operational Services to help accelerate your digital transformation. From the onset of your transformation journey, Advisory and Transformational Services focus on designing the transformation and creating a solution roadmap. Professional Services specializes in creative configurations with flawless and on-time implementation, and on-budget execution. Finally, operational services provides innovative new approaches like Flexible Capacity and Datacenter Care, to keep your business at peak performance. Hewlett Packard Enterprise is ready to bring together all the pieces of the puzzle for you, with an eye on the future, and make the complex simple.

---

### Recommended Support

#### HPE Proactive Care\* with 24x7 coverage, three year Support Service

HPE Proactive Care gives customers an enhanced call experience. When your products are connected to Hewlett Packard Enterprise, Proactive Care helps prevent problems and maintains IT stability by utilizing personalized proactive reports with recommendations and advice. This Service combines three years proactive reporting and advice with our 24x7 coverage, four hour hardware response time when there is a problem. This service also includes collaborative software support for Independent Software Vendors (ISVs), (Red Hat, VMWare, Microsoft, etc.) running on your HPE servers.

<https://www.hpe.com/h20195/v2/GetPDF.aspx/4AA3-8855ENW.pdf>

#### HPE Proactive Care\* with 6 hour call-to-repair commitment, three year Support Service

HPE Proactive Care gives customers an enhanced call experience. When your products are connected to Hewlett Packard Enterprise, Proactive Care helps prevent problems and maintains IT stability by utilizing personalized proactive reports with recommendations and advice. This Service combines three years' proactive reporting and advice with our highest level of hardware support – the HPE 24x7, six hour hardware call-to-repair. Hewlett Packard Enterprise is the only leading manufacturer who makes this level of coverage available as a standard service offering for your most valuable servers. This service also includes collaborative software support for Independent Software Vendors (ISVs), (Red Hat, VMWare, Microsoft, etc.) running on your HPE servers.

<https://www.hpe.com/h20195/v2/GetPDF.aspx/4AA3-8855ENW.pdf>

**NOTE:** \*HPE Proactive Care and HPE Proactive Care Advanced require that the customer connect their devices to make the most of these services and receive all the deliverables.

---

### HPE Education Services

Keep your IT staff trained making sure they have the right skills to deliver on your business outcomes. Book on a class today and learn how to get the most from your technology investment.

<http://www.hpe.com/ww/learn>

---

### HPE Support Center

The HPE Support Center is a personalized online support portal with access to information, tools and experts to support HPE business products. Submit support cases online, chat with Hewlett Packard Enterprise experts, access support resources or collaborate with peers.

Learn more <http://www.hpe.com/support/hpesc>

The HPE Support Center Mobile App\* allows you to resolve issues yourself or quickly connect to an agent for live support. Now, you can get access to personalized IT support anywhere, anytime. HPE Insight Remote Support and HPE Support Center are available at no additional cost with a HPE warranty, HPE Support Service or HPE contractual support agreement.

**NOTE:** \*HPE Support Center Mobile App is subject to local availability

---

---

## Service and Support

### Parts and materials

Hewlett Packard Enterprise will provide HPE-supported replacement parts and materials necessary to maintain the covered hardware product in operating condition, including parts and materials for available and recommended engineering improvements.

Parts and components that have reached their maximum supported lifetime and/or the maximum usage limitations as set forth in the manufacturer's operating manual, product quick-specs, or the technical product data sheet will not be provided, repaired, or replaced as part of these services.

The defective media retention service feature option applies only to Disk or eligible SSD/Flash Drives replaced by Hewlett Packard Enterprise due to malfunction.

---

### Related Services

#### **HPE Server Hardware Installation**

Provides for the basic hardware installation of HPE branded servers, storage devices and networking options to assist you in bringing your new hardware into operation in a timely and professional manner.

<https://www.hpe.com/h20195/V2/GetPDF.aspx/5981-9356EN.pdf>

**HPE Installation and Startup Service** provides for the installation and startup of HPE technology including BladeSystems, C-Class enclosure, HPE ProLiant c-Class and Integrity server blades, storage blades, SAN switch blades, HPE Virtual Connect modules (Ethernet and Fibre Channel), Ethernet network interconnects, and InfiniBand, as well as the installation of one supported operating system type (Windows® or Linux).

- Warranty and Support Services will extend to include HPE options configured with your server or storage device. The price of support service is not impacted by configuration details. HPE sourced options that are compatible with your product will be covered under your server support at the same level of coverage allowing you to upgrade freely. Installation for HPE options is available as needed. To keep support costs low for everyone, some high value options will require additional support. Additional support is only required on select high value workload accelerators, fibre switches, InfiniBand and UPS batteries over 12KVA. See the specific high value options that require additional support [HERE](#).

---

### For more information

Visit the Hewlett Packard Enterprise Service and Support [website](#).

## Summary of Changes

Date	Version History	Action	Description of Change
06-Aug-2018	Version 2	Changed	Added DL360 Cable Kit (867992-B21) and support for DL360 Gen10, DL385 Gen10, and VMware ESXi support.
04-Jun-2018	Version 1	New	Initial version.



**Sign up for updates**



**Hewlett Packard  
Enterprise**

© Copyright 2018 Hewlett Packard Enterprise Development LP. The information contained herein is subject to change without notice. The only warranties for Hewlett Packard Enterprise products and services are set forth in the express warranty statements accompanying such products and services. Nothing herein should be construed as constituting an additional warranty. Hewlett Packard Enterprise shall not be liable for technical or editorial errors or omissions contained herein.

Microsoft and Windows are registered trademarks or trademarks of Microsoft Corporation in the U.S. and/or other countries.

a00037242enw - 16117 - Worldwide - V2 - 06-Aug-2018